

Structural Design of Dam Sluice Gate Walkway Slabs: Retrofit and Replacement Options

Project Description

Introduction

Local utility identified reinforced concrete maintenance walkways at each of their dam's seven sluice gates as damaged and in need of repair or replacement. Walkways routinely used for maintenance and **pose life-safety hazard** for workers.

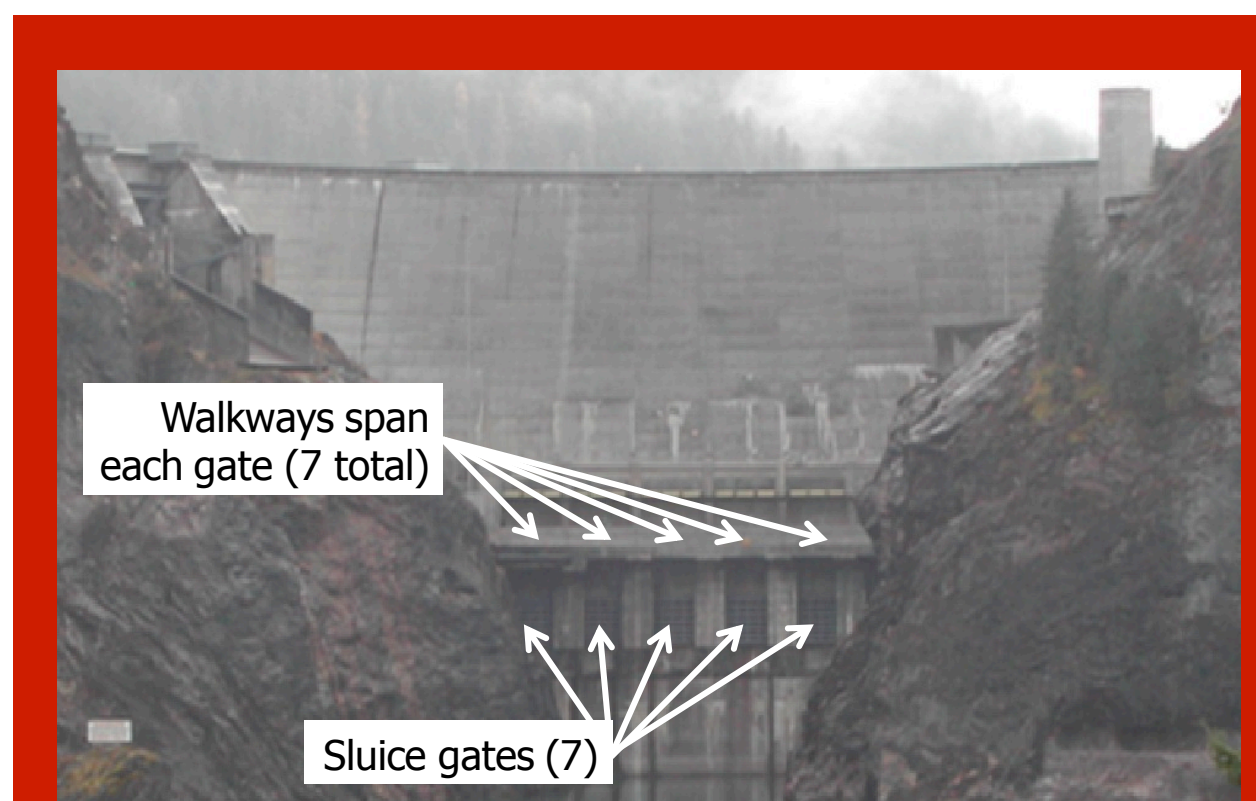

Dam with seven walkways

The Problem

- Existing slabs overloaded
- Deflections > 2.5 in
- Life-safety hazard**



Large deflections easily visible

Design Criteria

- 4 kip point, 100 psf distributed anywhere
- Deflections < span/360
- 50 year service life

Site-Specific Challenges

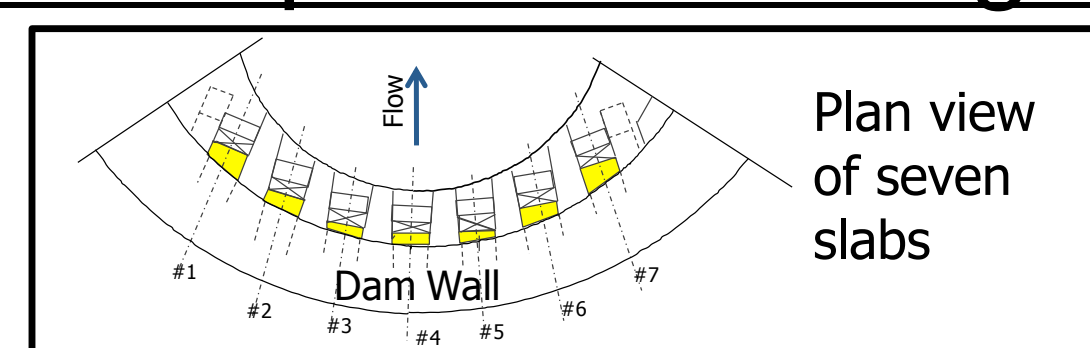

Plan view of seven slabs

- Remote location
- Varying geometry
- Walkway access
- Aggressive environment

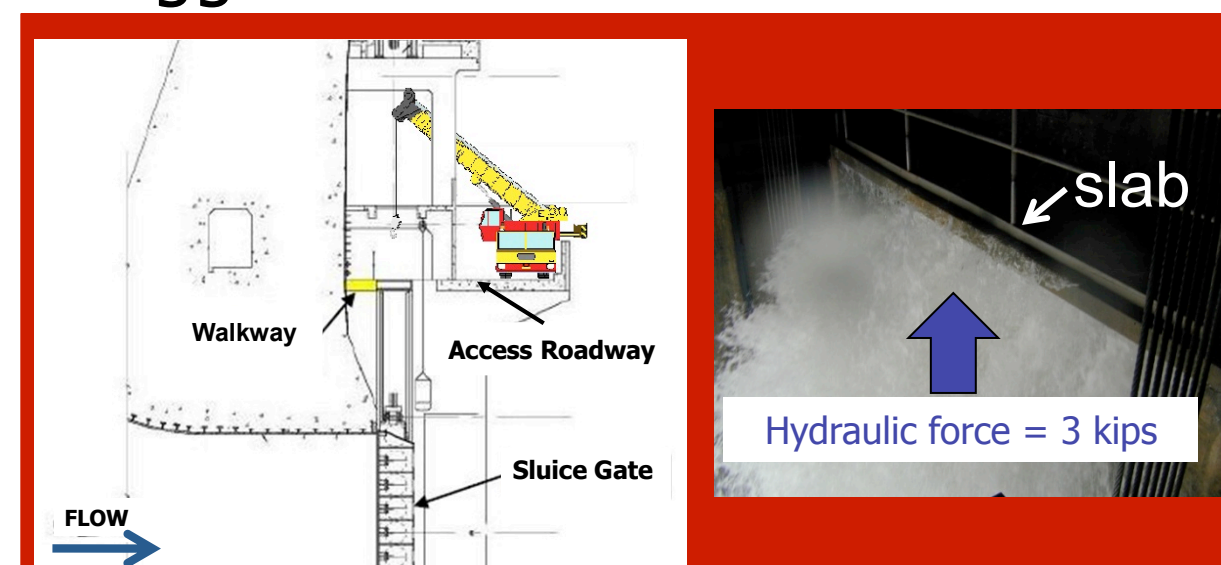

Limited crane access

Aggressive environment

Capstone Design Structure

- Five student team (2 female, 3 male)
- Worked with faculty advisor and two company liaisons – licensed civil engineer and project manager
- Weekly meetings with sponsor
- Major milestones:

Fall	Winter	Spring
Written Proposal	Analysis and Design	Final Report, Presentation

- Project highlights:
 - Site visit to dam
 - Professional presentations – project sponsor, local Structural Engineers Association and ASCE chapters
 - Sponsor fabrication shop visit to observe completion of connection design

Design Concepts

Steel Retrofit

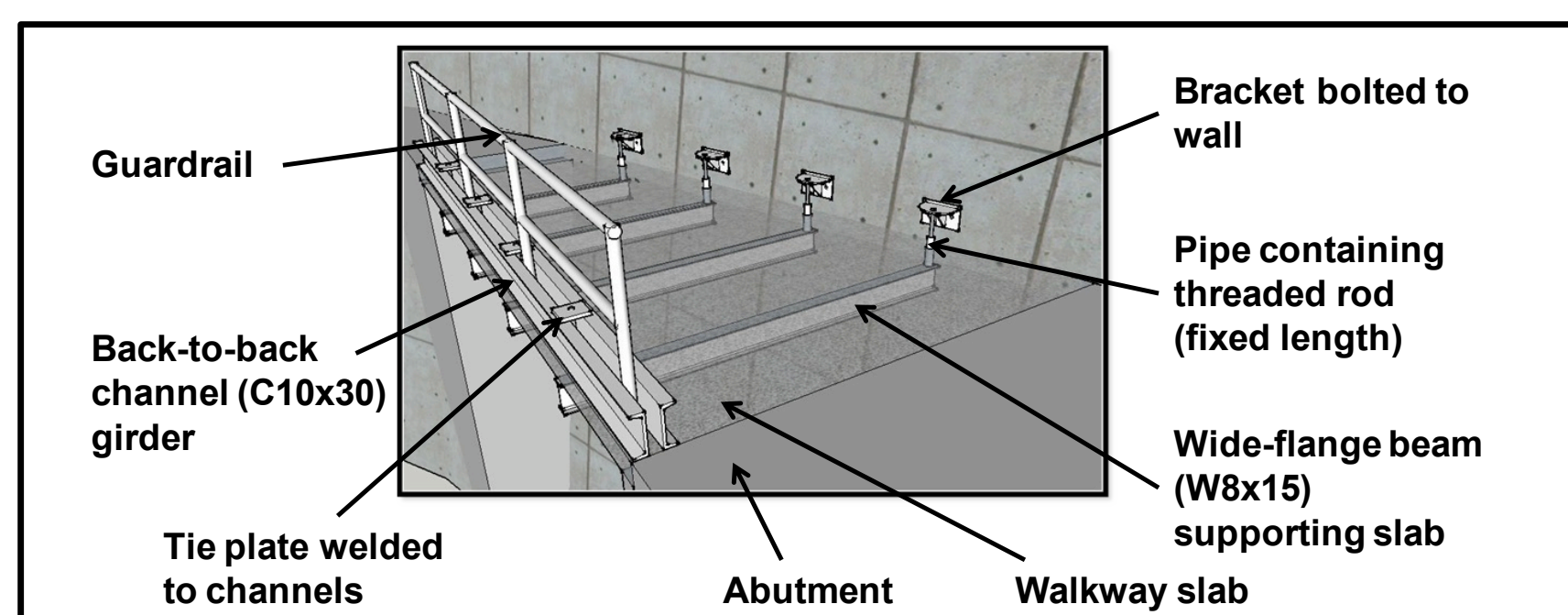

- Galvanized W8x15 beams span existing slabs
- Beams supported upstream by wall bracket, downstream by channel girder
- Threaded connections for constructability

Channel Girder Design

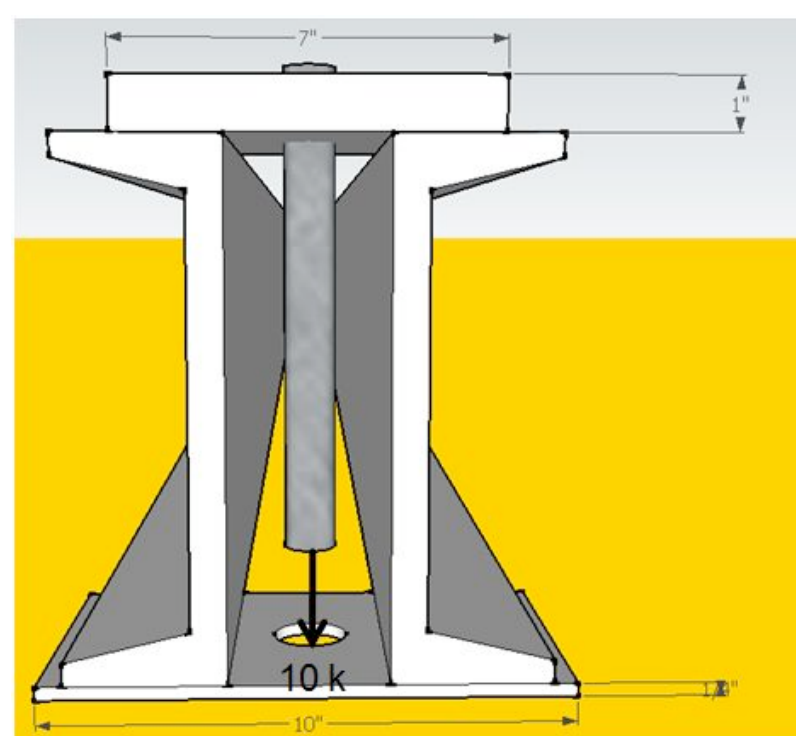

- C10x30 channels selected based on yielding, lateral-torsional buckling, and deflection
- Tie plates analyzed for flexure and shear

Wall Bracket Design

- Supports 10 kip load
- Moment capacity and demand graphed vs. position
- Plate thicknesses optimized

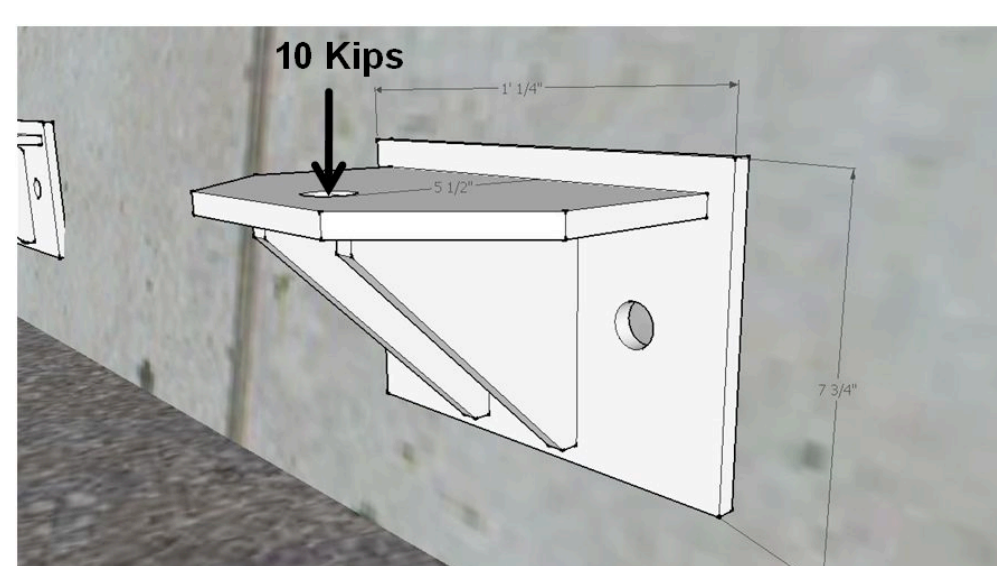

Reinforced Concrete Slab Demolition and Replacement

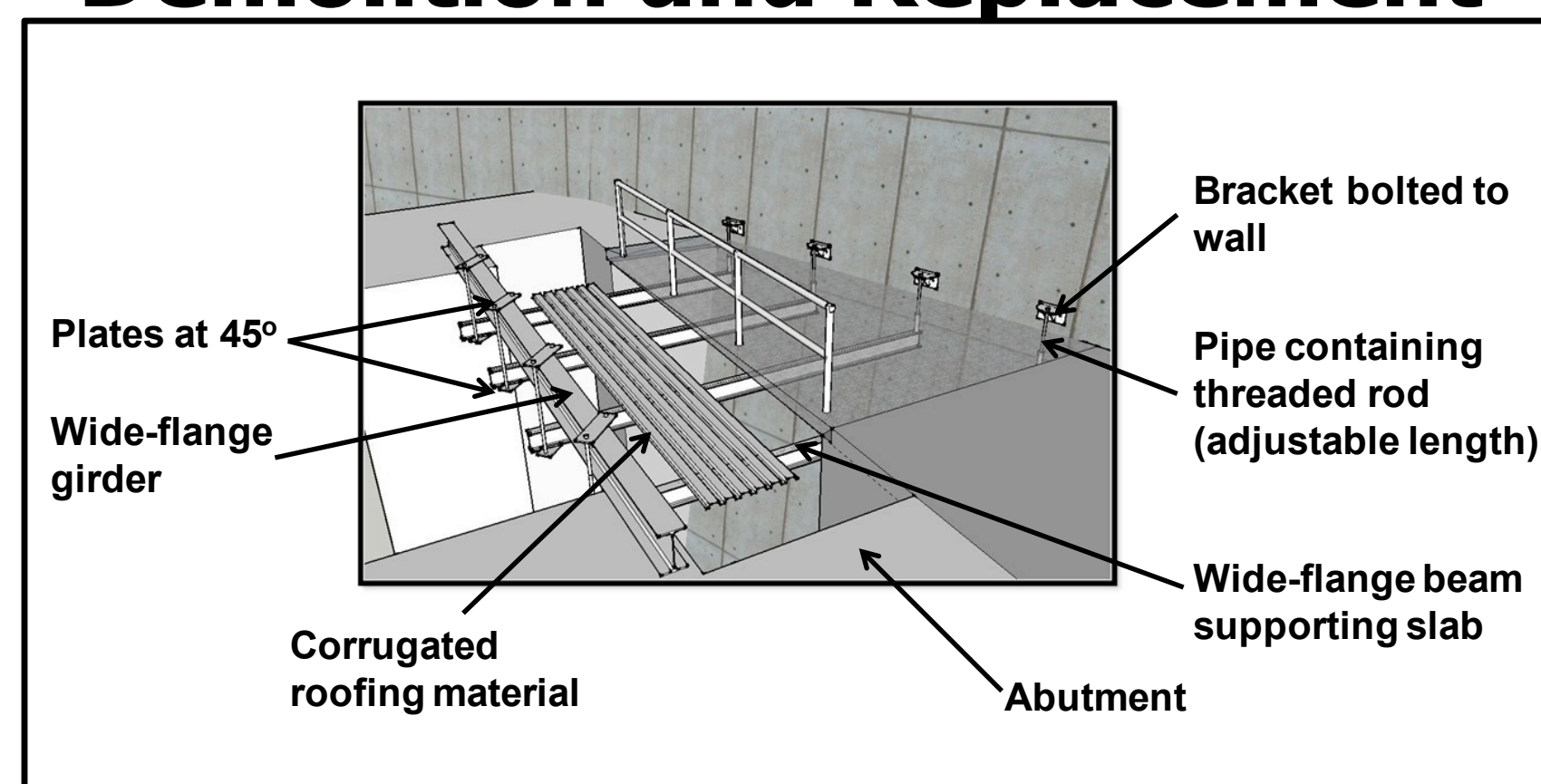

- Temporary steel shoring system
- Formwork constructed on temporary shoring and new reinforced concrete slabs cast

New Slab Design

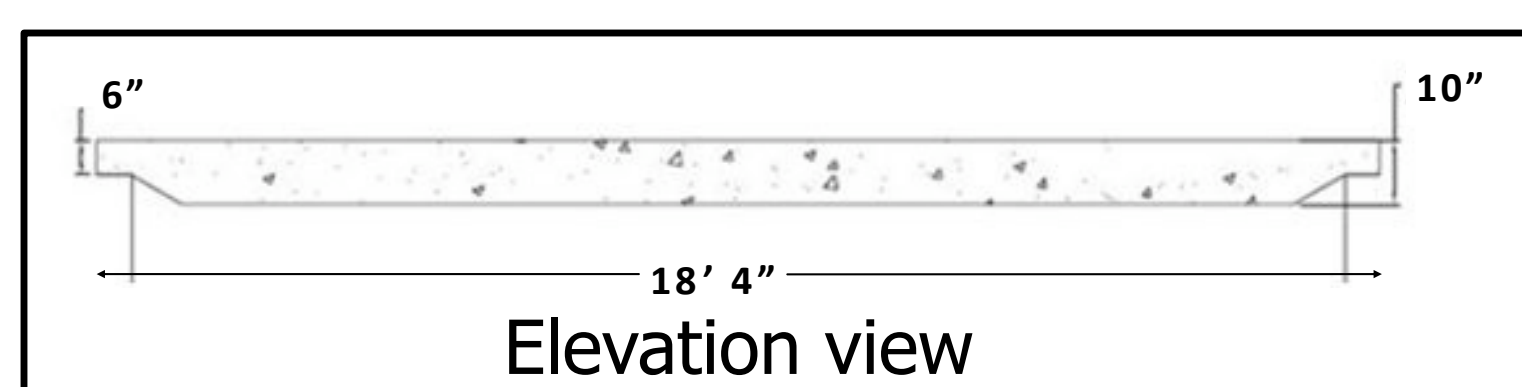

Elevation view

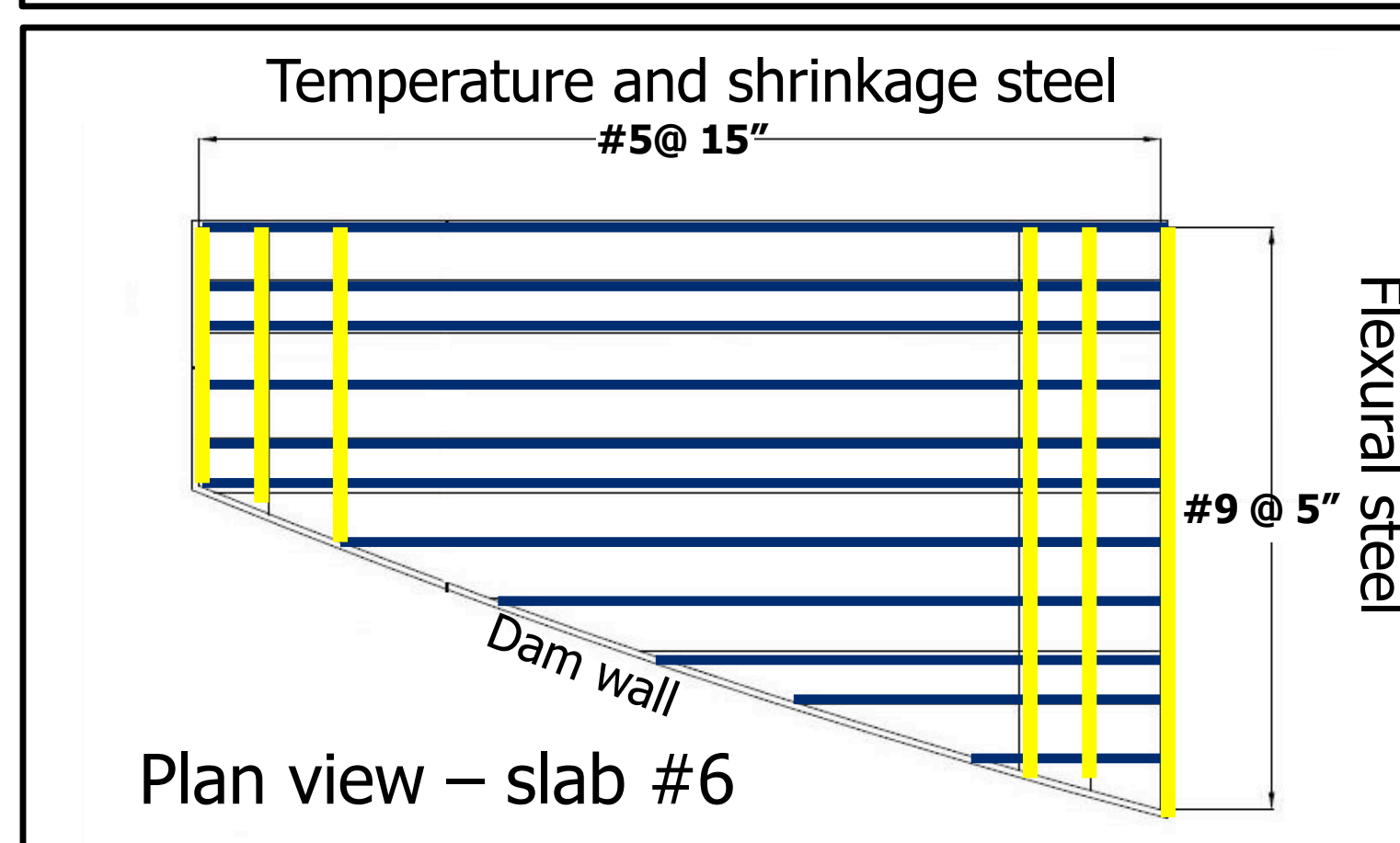

Plan view – slab #6

Project Deliverables

- Proposal – scope of work and deliverables for 30, 60 and 90% submittals
- Design Alternatives - four submitted, two selected
- Structural Calculations and Drawings
- Construction Specifications
- Construction Sequences
- Detailed Cost Estimates - retrofit and replacement options will cost \$56,000 and \$213,000, respectively.

Skills Developed

Technical

- Students learned to assess, analyze and make design recommendations for existing structure
- Worked with building codes, design specifications, design aids and computer-aided drafting
- Unique exposure to constructability and connection design

Communication

- Written – proposal, design calculations, final report, professional emails to sponsor
- Oral – presentations to senior design class, sponsor, local engineering chapters

Project Management

- Weekly meeting organized by team
- Rotating project manager responsibilities

Structural Design of Dam Sluice Gate Walkway Slabs: Retrofit and Replacement Options

A local utility company issued a Request for Proposal to our university's capstone design class for structural improvements to their dam facility. The company identified reinforced concrete service walkways at each of the dam's seven sluice gates as damaged and in need of repair or replacement. The walkways are routinely used by staff for dam maintenance, posing a life-safety issue.

There are a total of seven service walkways, each with varying geometries. The walkways were constructed for maintenance of the sluice gates and most commonly support loads from foot traffic as well as equipment. Each of these walkways is a doubly reinforced concrete slab spanning approximately 20 feet and supported by abutments extending from the main structure between the sluice gates. Excessive slab deflections and cracking were observed during a team visit of the site.

The utility company requested that the student team prepare two design options: (1) steel retrofit and (2) reinforced concrete slab demolition and replacement plan. The structures were to meet the strength and serviceability requirements set forth by the sponsor. The final design was to consider the site-specific challenges of the project, including the remote site location, aggressive climate to which the slabs were exposed and the limited access to the walkways. Additionally, students were to account for worker safety in the proposed construction process and to prevent debris from falling into the river below.

The steel retrofit involves adding structural members to increase the capacity of the existing slabs. On the upstream side, each member is supported by a bracket bolted to the dam wall. Downstream, the members are supported by two back to back channels that rest on the existing slab. The channels transfer loads directly into the supporting abutments. This retrofit is relatively simple to install and costs approximately \$56,000.

The full replacement plan requires the installation of a temporary steel bracing system to support demolition and construction. The replacement slabs have an increased depth of ten inches to meet the specified load requirements. This option provides the requested 50 year service life and costs approximately \$213,000. Additionally, the design and construction solution are more complicated to execute, compared to the steel retrofit.

The proposed designs were completed by a five-member senior design team during an academic year. Students met weekly with their faculty advisor and two sponsor company liaisons, one of whom is a licensed civil engineer, the other is a project manager. The team's design calculations were reviewed by the faculty advisor, sponsor liaisons and two external licensed structural engineers (SEs). Project highlights included a site visit, professional presentations to their class, the project sponsor and outside professional chapters (Structural Engineers Association and ASCE) and a visit to the sponsor fabrication shop to discuss connection design. The two final design packages contained structural calculations, engineering drawings, construction specifications, construction sequences and cost estimates. Throughout the year, students developed important technical, communication and project management skills to help prepare them for their future careers as practicing engineers.

Structural Design of Dam Sluice Gate Walkway Slabs: Retrofit and Replacement Options

I. Project Description

Introduction

A local utility company issued a Request for Proposal to our university's capstone design class for structural improvements to their dam facility. The company identified reinforced concrete service walkways at each of the dam's seven sluice gates as damaged and in need of repair or replacement. Figure 1 shows the dam with the walkways and sluice gates identified. The walkways are routinely used by staff for dam maintenance, posing a life-safety issue.

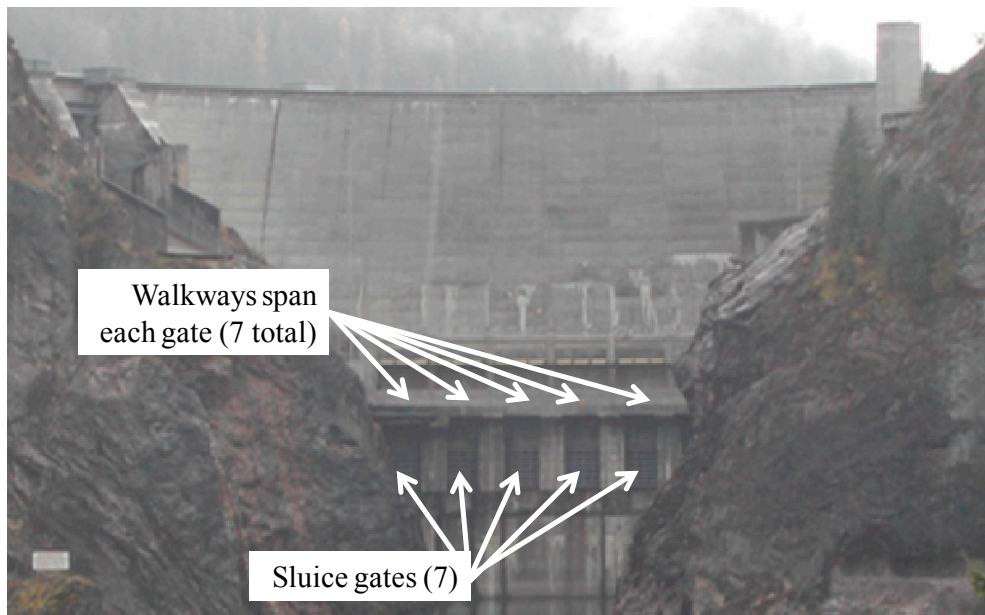

Figure 1. Dam with location of service walkways and sluice gates

The dam was completed in 1967. An extensive design and strong bedrock foundation permitted a slender cross-section with a structure functionally similar to an eggshell. The dam is 30 feet thick at the base and tapers to only eight feet at its top, holding back a reservoir depth of over 300 feet. The facility supplies 47% of their hydroelectric generation capacity.

Figure 2 presents a plan view of the dam, showing the seven service walkways and their unique geometries. The walkways were constructed for maintenance of the sluice gates and most commonly support loads from foot traffic as well as maintenance equipment. Each of these walkways is a doubly reinforced concrete slab spanning approximately 20 feet and supported by abutments extending from the main structure between the sluice gates.

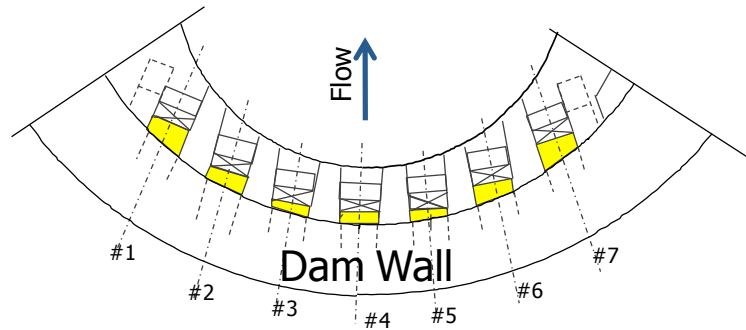

Figure 2. Plan view of seven maintenance walkways (shown in yellow) with varying geometries

Background

Figure 3 presents a photograph of one of the existing walkway slabs. Deflections were measured to be as large as 2.5 inches. During previous maintenance activities, these slabs were overloaded and permanently damaged by service crews. Although crews are now more conscientious of the load capacities, the past overloading excessively deflected the slabs posing a life-safety hazard for utility workers. Consequently, the walkways need to be strengthened or replaced.



Figure 3. Existing slab deflection (measured at site visit as up to 2.5 inches)

The capstone design team had to consider a number of site-specific challenges in their design:

Remote Dam Location and Slender Superstructure – The dam is located 20 miles from the nearest town and over 100 miles from the nearest major city. Thus, access to steel fabricators and ready-mix concrete suppliers is sparse and expensive. Furthermore, the superstructure deflects significantly with reservoir elevation fluctuations, requiring the use of expansion joints between replacement slabs and the existing structure.

Maintenance Walkway Location - The structural slabs are exposed to aggressive moisture conditions and wide temperature variations. When the sluice gates below the slabs are opened to regulate reservoir depth, some of the uncontrolled flow strikes the bottom of the slabs, subjecting them to a negative moment condition. The senior design team calculated the total hydraulic force caused by the discharge to be approximately three kips.

Maintenance Walkways Access - The walkways are served by a narrow roadway on the dam's face that is accessible only through a tunnel in the dam's west abutment. The tight clearances and the roadway's load capacity limit the use of heavy construction equipment such as concrete

trucks, concrete pumps, and the utility's crane. Figure 4 shows a typical cross section through the sluice gates. Crane access is further limited by overhead roof structures that were constructed after the installation of the original walkway. Demolition and construction plans needed to account for these restrictions.

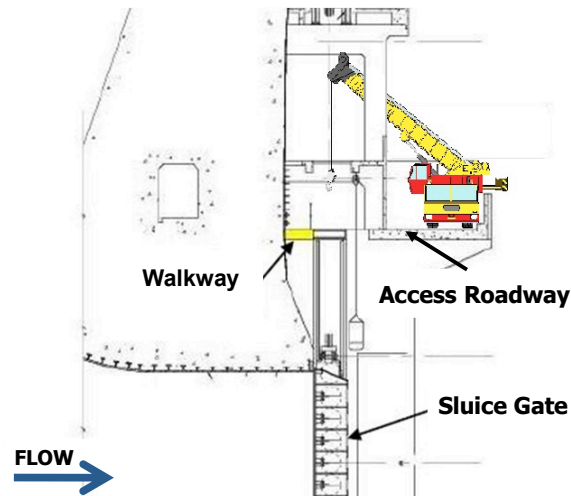

Figure 4. Typical Cross Section through Sluice Gate

Design Concepts

The team prepared two separate design concepts: (1) steel retrofit and (2) reinforced concrete slab demolition and replacement plan. The structures were to meet strength and serviceability criteria set forth by the project sponsor.

Steel Retrofit

The steel retrofit was presented as an economical alternative to a full replacement and was expected to increase the load capacity of the existing slabs to that specified by the sponsor while limiting further deflections. The retrofit involves installing beams under the slab to reduce the span length and thus the deflection.

Figure 5 shows the steel retrofit option. Four wide-flange beams support the floor slab, satisfying the deflection requirements. The beam supports consist of a pipe welded to the top flange at each end of the beam with a threaded inlet. The pipe extends above the beam through a core hole in the slab and a threaded rod connects the pipe to the supporting element for the beam. One end of the beam is supported by a bracket bolted to the wall 12 inches above the slab. The other side does not have a wall to support connection brackets, so a girder extends across the slab perpendicular to the beam for support. The girder is as long as the slab and will transfer the load through the slab into the existing abutments. The girder consists of back-to-back channels spaced three inches apart with the existing guardrail between them. A $\frac{1}{4}$ inch plate is welded to the bottom of the channels and a one inch plate to the top of the channels. These members brace the channels together. The top plate has a $1\frac{1}{16}$ inch hole to accommodate the threaded rod and supports the pipe and beam.

Rebar corrosion in the existing slabs is a concern and the retrofit design assumes 100% strength (non-corroded) of 40 ksi rebar. Therefore, the design requires that the existing rebar be checked using a corrosion analysis instrument (Proceq Canin). If the rebar is not corroded, the retrofit may be carried out. If corrosion is found, the design strength of the slabs should be reduced, or if corrosion is extensive, it may be necessary to pursue the full replacement option. It is also essential to seal the cracks in the bottom of the slabs so that water will not penetrate into the cracks, consequently, into the rebar.

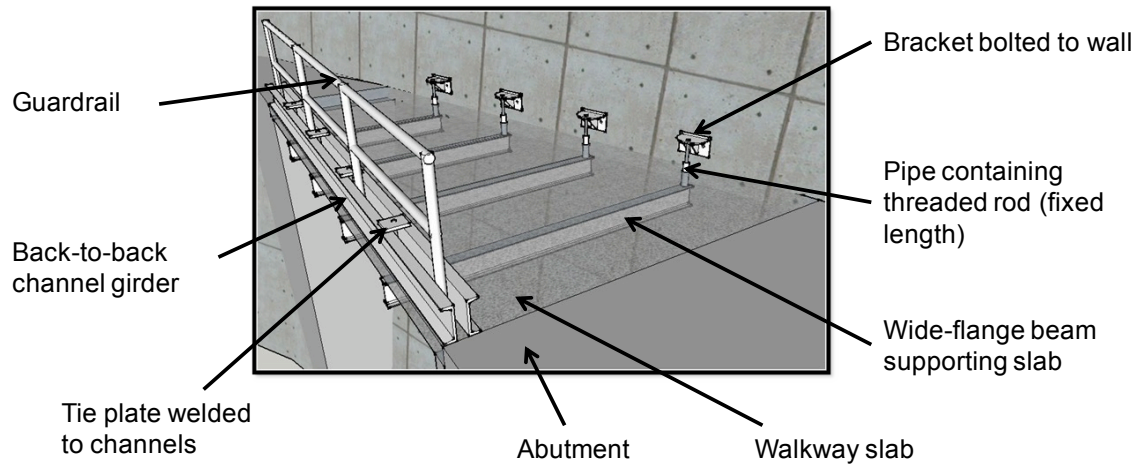

Figure 5. Completed Steel Retrofit

Reinforced Concrete Slab Demolition and Replacement

Although the retrofit is the more sustainable and cost effective option, the project sponsor also requested a design for demolition and replacement of the existing slabs that guarantees a 50 year design life. Deteriorated slabs, or those damaged in the retrofit process, may be replaced using this design. Similar to the retrofit concept, demolition involves the installation of wide-flange beams under the slab. In this case, the beams serve to support the process of removal of the damaged slabs. Figure 6 shows the demolition bracing system.

For the new walkways to have sufficient capacity, the replacement design requires an increased slab depth and reinforcing steel. The limiting parameter for the beam spacing is the specified maximum span length of the corrugated roofing material (Vulcraft B16). This roofing material is placed above the beams to prevent debris from the existing slab from falling into the river during demolition. Environmental regulations require strict control of any waste material contaminating the river, thus, extreme caution was taken during the design process to prohibit such an occurrence. The roofing material serves as formwork for the cast-in-place replacement design.

The supporting beams connect to the dam wall in the same manner as described in the retrofit option. In the downstream end, a wide-flange girder rests between the abutments. The beams connect to the girder with plates on the top and bottom flanges oriented at 45°, as shown Figure 6, using threaded rods.

After the existing slabs are properly supported, the demolition process begins by elevating the corrugated metal deck support until it is snug with the bottom of the existing slab. Due to the placement of the walkways and the limited crane capacity, the slabs will be cut into pieces

weighing approximately 200 pounds to be carted away from the construction area. These cuts will be made with a diamond saw blade and the slurry will be contained with a shop-vac on site to prevent any environmental damage to the river.

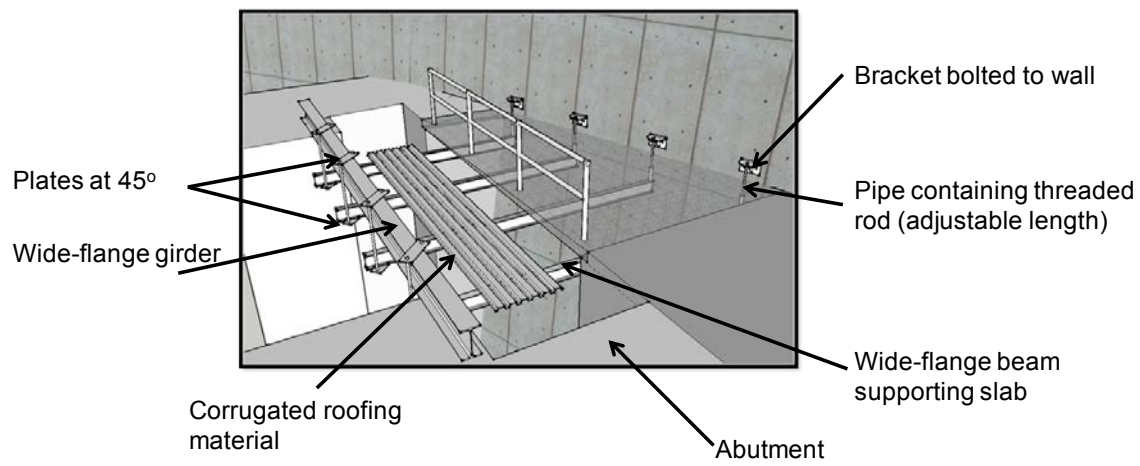

Figure 6. Completed Demolition Bracing System

Once the existing slab is removed, the crew lays the formwork and steel reinforcement. The concrete is poured with a truck-mounted line pump routed through the utility access door. Concrete is vibrated during placement and requires a medium broom finish perpendicular to the direction of foot travel.

The bracing system was designed for the largest slabs, to size members with the capacity to support each of the seven walkways. To keep this portion of the dam operational and save on cost, the demolition and replacement process is designed to replace one slab at a time. Construction begins with the largest slab (slabs 7 or 1) and continues around the face of the dam as the slabs cure and develop enough strength to support the design loads.

Project Deliverables

Project deliverables included:

- Proposal- The written proposal included the scope of work, and a list of deliverables for the 30%, 60%, 90%, and 100% phases and a proposed schedule for each submittal.
- Design Alternatives - Four design alternatives were presented in the 30% submittal. The project sponsor chose the steel retrofit and the demolition and replacement plan.
- Structural Calculations and Drawings – The final report included the design calculations and AutoCAD drawings for the steel retrofit and demolition and replacement concepts.
- Construction Specifications - Comprehensive specification documents for steel and concrete construction in accordance with the standards of the Construction Specifications Institute were prepared.
- Construction Sequences - Construction sequences for the steel retrofit and demolition and replacement design were presented.
- Detailed Cost Estimates - The team prepared final cost estimates for both steel retrofit and demolition and replacement designs. The retrofit and replacement options will cost \$56,000 and \$213,000, respectively.

II. Collaboration of Faculty, Students and Licensed Professional Engineers

At our institution, senior Civil and Environmental Engineering students are required to complete a year-long, real-world, capstone design project. A team of five students (two female, three male) was assigned to the project described previously, working under the guidance of a faculty advisor and two company sponsor liaisons, one of whom is a licensed civil engineer and the other a project manager.

As part of the capstone course, students completed: (1) a project proposal during the fall quarter, (2) the major analysis and design work during the winter, and (3) a final report and presentation in the spring quarter. To accomplish these tasks, the student team held weekly meeting with their faculty advisor and company liaisons. They also gave two presentations for the sponsor – one in the fall detailing the proposal and one in the spring explaining the final design. These presentations were attended by other licensed civil engineers, project managers and a licensed structural engineer (SE) from the company.

III. Benefit to Public Health, Safety and Welfare

The project addressed two worker safety concerns and one public health and welfare issue:

Maintenance work on existing slabs - The existing damaged walkway slabs pose a life-safety hazard for dam employees. The sluice gates routinely require maintenance. Much of the equipment involved is very heavy and must be placed on the slabs during cleaning and repair. For example, a single wheel from the sluice gate weighs over one kip. The existing capacity of the slabs (assuming no rebar corrosion) was estimated to be no greater than ten kips. Given the excessive deflections and cracking observed on the walkways, the capacity may be much less.

Construction for retrofit or replacement options – Construction of the retrofit or replacement option is challenging because there is no access below the slab without the use of complex scaffolding. Construction worker safety was considered in the design by not requiring any person to go below the slabs. This design protects against workers being struck by falling debris.

River preservation – Construction work occurs directly over the river. All designs included methods to prevent any debris from falling into the water and causing contamination.

IV. Multidiscipline and Allied Profession Participation

The project included a number of opportunities for the students to interact with other disciplines and professional engineers. Specifically, the students:

Conducted a site visit - The visit included a tour of the dam facility in which students interacted with utility operators and workers to learn about the functionality of the deficient walkways. Students took field measurements of the existing slab dimensions and deflections during the tour.

Interacted with practicing engineers – The team gave presentations to the local chapter of the Structural Engineers Association and the local chapter of the American Society of Civil Engineers (ASCE). The presentation to the Structural Engineers Association occurred in the fall at the beginning of the project and solicited feedback from interested licensed SEs. Throughout the year, the students had follow-up meetings with a number of these SEs to discuss their design concepts. Additionally, the team's final project report was reviewed by two external SEs.

Learned about connection design – The students visited the sponsor’s fabrication shop to discuss connection detailing and observe production of one of their final connection designs. They received feedback from the fabricators about how to improve the design and drawings.

V. Knowledge and Skills Gained

The senior design experience is unique in that it helps students to develop a variety of important skills needed for practicing engineers.

Technical - The students learned how to assess and analyze an existing structure and then prepare design recommendations to remedy structural deficiencies. This process included using:

- *Building codes* - 2009 International Building Code, ASCE 7-05 Minimum Design Loads for Structures and Other Buildings
- *Design specifications* - AISC Steel Construction Manual 13th Ed., ACI: 318-08 Building Code Requirements for Structural Concrete and Commentary and
- *Design aids* - Hilti North America Technical Product Guide 4.2.4, Vulcraft Product Guide
- *Computer aided drafting* - AutoCAD 2007

Additionally, the students learned about constructability and detailed connection design, topics not covered in traditional courses. Their final designs addressed site-specific issues and included detailed construction specifications (Construction Specifications Institute) and sequencing.

Communication - During the year students developed both writing and speaking skills. The students submitted a written proposal and a final report for the capstone course. Students provided detailed engineering calculations to the liaison throughout the year and received feedback. The students were also responsible for sending professional emails to the project liaisons. The team prepared oral presentations for their senior design course, the project sponsor and professional engineering societies (Structural Engineers Association and ASCE).

Project Management and Leadership - The team organized weekly meetings with the faculty advisor and sponsor liaisons. Throughout the year, students took turns serving as the project manager. The project manager was responsible for preparing the agenda, leading meetings, assigning tasks and tracking overall progress.

Summary

A local utility company requested that a senior design team at our university design structural repair and replacement options for maintenance walkways at their dam facility. The walkways were severely deteriorated due to overloading, exhibiting excessive deflections and cracking. Throughout the course of the year, the student conducted a site visit, met weekly with the company liaisons, one of whom is a licensed professional engineer, and gave presentations to their class, the project sponsor and outside professional chapters (Structural Engineers Association and ASCE). Two design options were produced by the team: (1) a steel retrofit and (2) reinforced concrete slab demolition and replacement. Both designs include structural calculations, engineering drawings, construction specifications, construction sequences and cost estimates. Students developed many important technical, communication and project management skills for their future careers as practicing engineers.